

# E 51 A

## ELECTRONIC TEMPERATURE CONTROLLER



### OPERATING INSTRUCTIONS

Vr. 01 (ENG) - 06/08  
cod.: ISTR-ME51AENG1

**SIKA DR. SIEBERT & KÜHN**

GmbH & Co. KG  
Struthweg 7-9  
34260 Kaufungen  
Germany  
Tel.: 05605 / 8030  
Fax: 05605 / 80354

#### FOREWORD



This manual contains the information necessary for the product to be installed correctly and also instructions for its maintenance and use; we therefore recommend that the utmost attention is paid to the following instructions and to save it.

This document is the exclusive property of SIKA which forbids any reproduction and divulgation, even in part, of the document, unless expressly authorized.

SIKA reserves the right to make any formal or functional changes at any moment and without any notice.

Whenever a failure or a malfunction of the device may cause dangerous situations for persons, things or animals, please remember that the plant has to be equipped with additional devices which will guarantee safety.

SIKA and its legal representatives do not assume any responsibility for any damage to people, things or animals deriving from violation, wrong or improper use or in any case not in compliance with the instrument's features.

## INDEX

- 1 INSTRUMENT DESCRIPTION**
  - 1.1 GENERAL DESCRIPTION
  - 1.2 FRONT PANEL DESCRIPTION
- 2 PROGRAMMING**
  - 2.1 FAST PROGRAMMING OF SET POINT
  - 2.2 STANDARD MODE PARAMETERS PROGRAMMING
  - 2.3 PARAMETER PROTECTION USING THE PASSWORD
  - 2.4 CUSTOMIZED MODE PARAMETER PROGRAMMING (PARAMETERS PROGRAMMING LEVEL)
  - 2.5 RESET PARAMETERS TO DEFAULT VALUE/LEVEL
- 3 INFORMATION ON INSTALLATION AND USE**
  - 3.1 PERMITTED USE
  - 3.2 MECHANICAL MOUNTING
  - 3.3 ELECTRICAL CONNECTIONS
  - 3.4 ELECTRICAL WIRING DIAGRAM
- 4 FUNCTIONS**
  - 4.1 MEASURING AND VISUALIZATION
  - 4.2 TEMPERATURE CONTROL
  - 4.3 COMPRESSOR PROTECTION FUNCTION AND DELAY AT POWER-ON
  - 4.4 TEMPERATURE ALARM
  - 4.5 ON / STAND-BY FUNCTION
  - 4.6 KEYBOARD LOCK FUNCTION
- 5 PROGRAMMABLE PARAMETERS TABLE**
- 6 PROBLEMS , MAINTENANCE AND GUARANTEE**
  - 6.1 SIGNALLING
  - 6.2 CLEANING
  - 6.3 GUARANTEE AND REPAIRS
- 7 TECHNICAL DATA**
  - 7.1 ELECTRICAL DATA
  - 7.2 MECHANICAL DATA
  - 7.3 MECHANICAL DIMENSIONS, PANEL CUT-OUT AND MOUNTING
  - 7.4 FUNCTIONAL DATA
  - 7.5 INSTRUMENT ORDERING CODE

## 1 - INSTRUMENT DESCRIPTION

### 1.1 - GENERAL DESCRIPTION

The model E51A is a digital electronic temperature controller that is typically used in cooling applications with ON/OFF control mode. The instrument has one relay output and one input for PTC or NTC temperature probes.

### 1.2 - FRONT PANEL DESCRIPTION

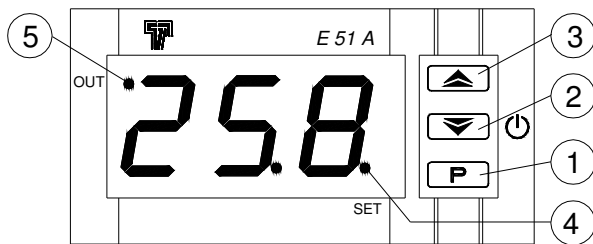

#### 1 - Key P :

Used for setting the Set point (press and release) and for programming the function parameters (hold pressed for 5 sec.)

In programming mode is used to enter in parameters edit mode and confirm the values.

In programming mode it can be used together with the UP key to change the programming level of the parameters.

When the keyboard is locked it can be used together with the UP key to unlock the keyboard.

#### 2 - Key DOWN :

In programming mode is used for decreasing the values to be set and for selecting the parameters.

In normal mode and if par. "Fb" = 1 it can be used to turning on and off (stand-by) the device (hold pressed for 1 sec.)

#### 3 - Key UP :

In programming mode is used for increasing the values to be set and for selecting the parameters.

In programming mode can be used to come back in normal mode (hold for 2 sec.) and to change parameters level (with key P).

Pressed together with the key P for 5 sec. allow the keyboard unlock

#### 4 - Led SET :

In programming mode indicates the programming level of the parameters. In normal mode it also serves to indicate the Stand-by status and blinked when a key is pressed.

5 - Led OUT : Indicates the output status (compressor or temperature control device) on (on), off (off) or inhibited (flashing).

## 2 - PROGRAMMING

### 2.1 - FAST PROGRAMMING OF SET POINT

Press the key P then release it and the display will show “SP” alternating with the set value.

To change it press the UP key to increase the value or DOWN to decrease it.

These keys increase or decrease the value one digit at a time, but if the button is pressed for more than one second the value increase or decreases rapidly, and after two seconds pressed, the speed increases even more to all the desired valued to be reached rapidly.

When the desired value is set press the key P to exit from Set Point programming mode.

Exiting the Set mode is achieved by pressing the P key or automatically if no key is pressed for 15 seconds. After that time the display returns to the normal function mode.

### 2.2 - STANDARD MODE PARAMETERS PROGRAMMING

To access the instrument's function parameters when password protection is disable, press the key P and keep it pressed for about 5 seconds, after which the display will visualised the code that identifies the first parameter.

Using the UP and DOWN keys, the desired parameter can be selected and pressing the P key, the display will alternately show the parameter code and its setting that can be changed with the UP and DOWN keys.

Once the desired value has been set, press the key P again: the new value will be memorised and the display will show only the code of the selected parameter.

Pressing the UP and DOWN keys, it is possible to select another parameter and change it as described.

To exit the programming mode, do not press any key for about 30 seconds, or keep the UP key pressed for 2 sec. until it exits the programming mode.

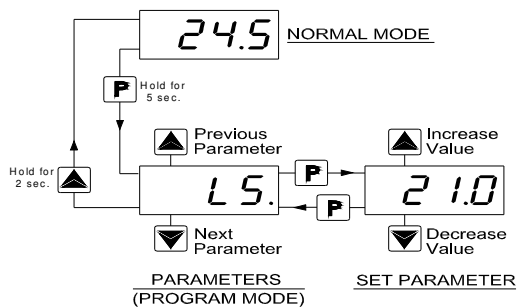

### 2.3 - PARAMETER PROTECTION USING THE PASSWORD

The instrument has a parameter protection function using a password that can be personalised, through the “PP” parameter.

If one wishes to have this protection, set the password number desired in the parameter “PP”.

When the protection is activate, press the P key to access the parameters and keep it press for about 5 seconds, after which the display will show “r.P” .

At this point press P, the display show “0”, using the UP and DOWN keys, set the password number programmed and press the key “P”.

If the password is correct, the display will visualise the code that identifies the first parameter and it will be possible to program the instrument in the same ways described in the previous section.

Protection using a password can be disabled by setting the parameter “PP” = 0F.

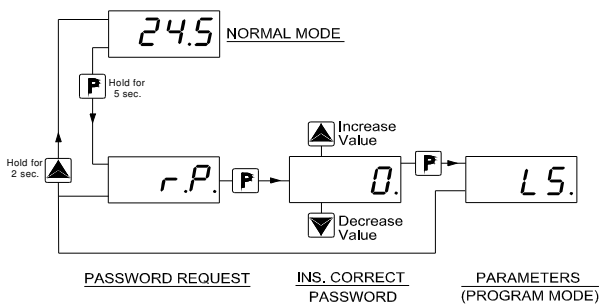

**Note:** If the Password gets lost, just cut off the supply, push P key and keeping it pressed for 5 seconds whilst switching on the supply to the instrument.

In this way it's possible to have access to all the parameters, verify and modify the par. “PP”.

## 2.4 - CUSTOMIZED MODE PARAMETER PROGRAMMING (PARAMETERS PROGRAMMING LEVEL)

The password protection hides all the configuration parameters behind a factory set password to avoid unwanted changes being made to the programming of the controller.

To make a parameter accessible without having to enter a password when password protection is activate follows this procedure.

Enter the programming using the Password and select the parameter which is desired to be accessible with no password protection.

Once the parameter has been selected, if the SET led is blinking, this means that the parameter is programmable by entering the password (it's then "protected") if it's instead on, this means the parameter is programmable without password (not protected).

If you want to change the accessibility of the parameter push P key, keep it pressed and press together also the key UP.

The led SET will change its state indicating the new access level of the parameter (on = not protected; blinking = protected by password).

In case some parameters are not protected, when one tries to have access at the programming, the display will show all the parameters not protected and the par. "r.P" (through which will be possible to have access to the "protected" parameters.)

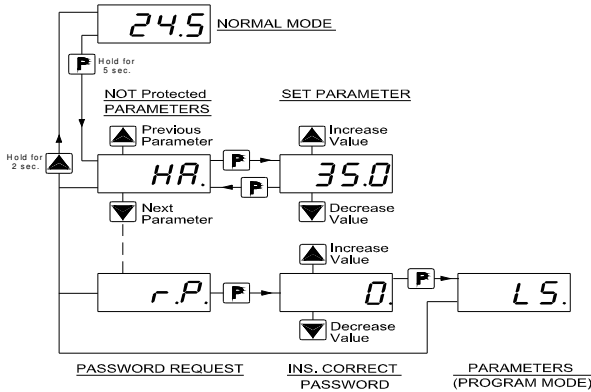

## 2.5 - RESET PARAMETERS TO DEFAULT VALUE/LEVEL

The instrument allows the reset of the parameters to values programmed in factory as default.

To restore to the values of default the parameters set the value -48 to "r.P" password request.

Once confirmed the password with the key P the display it shows "--" for 2 sec. therefore the instrument effects the parameters reset.

## 3 - INFORMATION ON INSTALLATION AND USE

### 3.1 - PERMITTED USE



The instrument has been projected and manufactured as a measuring and control device to be used according to EN60730-1 for the altitudes operation until 2000 ms.

The use of the instrument for applications not expressly permitted by the above mentioned rule must adopt all the necessary protective measures.

The instrument CANNOT be used in dangerous environments (flammable or explosive) without adequate protection.

The installer must ensure that EMC rules are respected, also after the instrument installation, if necessary using proper filters.

Whenever a failure or a malfunction of the device may cause dangerous situations for persons, thing or animals, please remember that the plant has to be equipped with additional devices which will guarantee safety.

### 3.2 - MECHANICAL MOUNTING

The instrument, in case 65 x 33 mm, is designed for flush-in panel mounting.

Make a hole 58 x 25 mm and insert the instrument, fixing it with the provided special brackets.

We recommend that the gasket is mounted in order to obtain the front protection degree as declared.

Avoid placing the instrument in environments with very high humidity levels or dirt that may create condensation or introduction of conductive substances into the instrument.

Ensure adequate ventilation to the instrument and avoid installation in containers that house devices which may overheat or which may cause the instrument to function at a higher temperature than the one permitted and declared.

Connect the instrument as far away as possible from sources of electromagnetic disturbances such as motors, power relays, relays, solenoid valves, etc.

### 3.3 - ELECTRICAL CONNECTION

Carry out the electrical wiring by connecting only one wire to each terminal, according to the following diagram, checking that the power supply is the same as that indicated on the instrument and that the load current absorption is no higher than the maximum electricity current permitted.

As the instrument is built-in equipment with permanent connection inside housing, it is not equipped with either switches or internal devices to protect against overload of current: the installation will include an overload protection and a two-phase circuit-breaker, placed as near as possible to the instrument, and located in a position that can easily be reached by the user and marked as instrument disconnecting device which interrupts the power supply to the equipment.

It is also recommended that the supply of all the electrical circuits connected to the instrument must be protect properly, using devices (ex. fuses) proportionate to the circulating currents.

It is strongly recommended that cables with proper insulation, according to the working voltages and temperatures, be used. Furthermore, the input cable of the probe has to be kept separate from line voltage wiring. If the input cable of the probe is screened, it has to be connected to the ground with only one side.

Whether the instrument is 12 V version it's recommended to use an external transformer TCTR, or with equivalent features, and to use only one transformer for each instrument because there is no insulation between supply and input.

We recommend that a check should be made that the parameters are those desired and that the application functions correctly before connecting the outputs to the actuators so as to avoid malfunctioning that may cause irregularities in the plant that could cause damage to people, things or animals.

### 3.4 - ELECTRICAL WIRING DIAGRAM

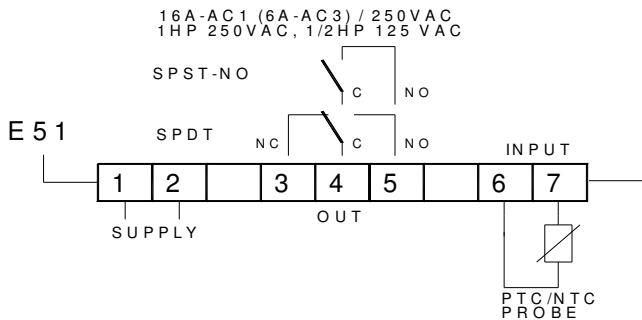

## 4 - FUNCTIONS

### 4.1 - MEASURING AND VISUALIZATION

Via the parameter "ru", it is possible to select the temperature unit of measurement (°C or °F) and, through the parameter "dP", the resolution of the desired measurement (oF=1°; on=0,1°).

The instrument allows the measuring to be calibrated, that can be used for re-calibrating the instrument according to application needs, through the parameters "CA". Using the parameter "Ft", it is possible to set the time constant for the software filter for measuring the input values to be able to reduce the sensitivity to measurement disturbances (increasing the time).

### 4.2 - TEMPERATURE CONTROL

The regulation mode of the instrument is ON/OFF and acts on the output "Out" depending on the measuring of probe, of the Set Point "SP", the intervention differential "d" and the function mode "HC".

Depending on the function mode preprogrammed on the parameter "HC" the differential is automatically considered by the regulator with positive values for a Refrigeration control ("HC"=C) or with negative values for a heating control ("HC"=H).

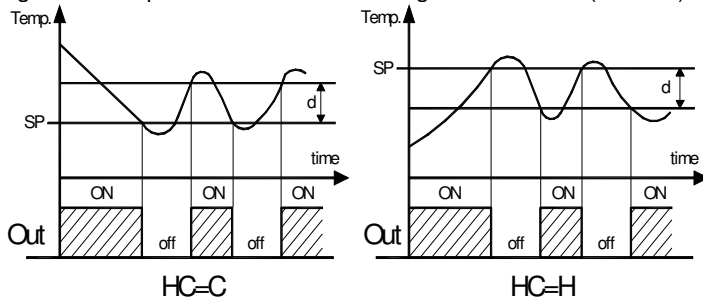

In the event of probe error, it is possible to set the instrument so that that the output "Out" continues to work in cycles according to the times programmed in the parameter "t1" (activation time) and "t2" (deactivation time).

If an error occurs on the probe the instrument activates the output for the time "t1", then deactivates it for the time "t2" and so on whilst the error remains.

Programming "t1" = oF the output in probe error condition will remain switched off.

Programming instead "t1" to any value and "t2" = oF the output in probe error condition will remain switched on.

Remember that the temperature regulation function can be conditioned by "Compressor Protection Functions and delay at power-on"

### 4.3 - COMPRESSOR PROTECTION FUNCTION AND DELAY AT POWER-ON

The function "Compressor Protection" carried out by the machine aims to avoid close start ups of the compressor controlled by the instrument in cooling applications.

This function foresees 3 time controls on the switching on of the "Out" output associated with the temperature regulation request.

The protection consists of preventing the output being switched on during the times set in the parameters "P1", "P2" and "P3" and therefore that any activation occurs only after all the times has finished.

First control (par. "P1") foresees a delay to the output activation (switching-on delay).

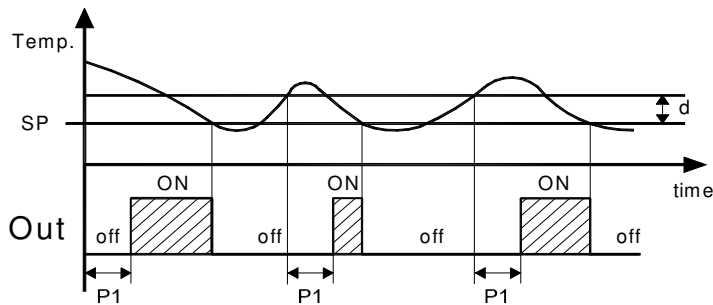

Second control (par. "P2") foresees an inhibition to the activation of the output by a time delay that starts when the output is turning off (delay after switching-off).

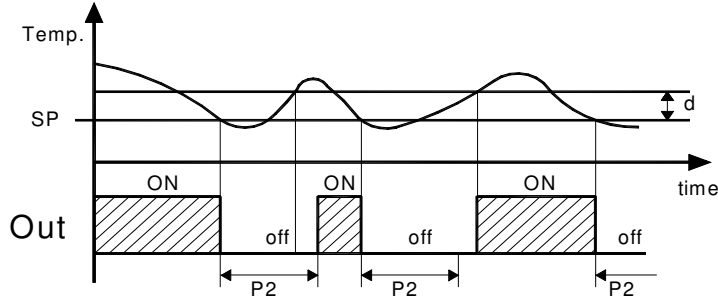

Third control (par. "P3") foresees an inhibition to the activation of the output "Out" by a time delay that starts when the output was turning on last time (delay between switching-on).

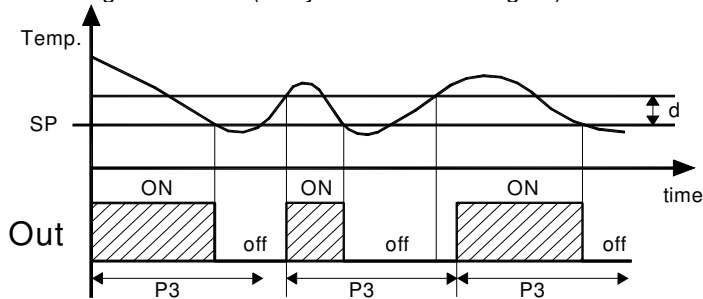

During the output inhibition the led OUT blinking.

It is also possible to prevent activation of the output after the instrument is turned on, for the time set in the parameter "od".

During the power on delay phase, the display shows the indication **od**, alternating with the normal visualisation.

All the functions are disabled by relative parameters = oF.

#### 4.4 - TEMPERATURE ALARMS

The temperature alarms, that are relative type, work according to the probe measurement, the alarm thresholds set in parameters "HA" (relative maximum alarm) and "LA" (relative minimum alarm) and the relative differential "Ad".

Using some parameters it is also possible to delay the enablement and the intervention of these alarms.

These parameters are:

"PA" - is the temperature alarm exclusion time on switching on the instrument if the instrument is in alarm status when it is switched on. If the instrument at power-on is not in alarm conditions the time "PA" is not considered.

"At" - is the temperature alarm delay activation time

The temperature alarm is enabled at the end of exclusion time and is enabled after the "At" time when the temperature measured by the probe exceeds the value ["SP"+"HA"] or or goes below the value ["SP"-LA].

In alarm conditions the instrument visualises on the display:

- Alternately **HI** and the measured temperature for maximum alarm
- Alternately **LO** and the measured temperature for the minimum alarm

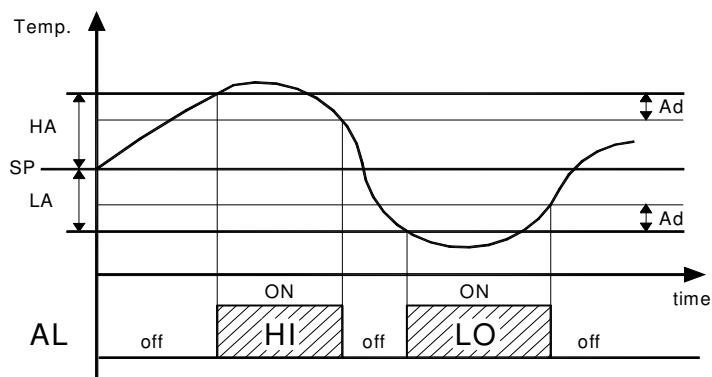

The maximum and minimum temperature alarms can be disabled by setting the relative parameters "HA" and "LA" = oF.

#### 4.5 - ON / STAND-BY FUNCTION

The instrument, once powered up, can assume 2 different conditions:

- ON : means that the controller uses the control functions.

- STAND-BY : means that the controller does not use any control function and the display is turned off except for the led SET

If there is no power, and then power returns, the system always sets itself in the condition it was in before the black-out.

The ON/Stand-by function can be selected using the key DOWN if the parameter "Fb" = 1.

Pressing the key DOWN for at least 1 sec., it is possible to switch the instrument from the ON status to Stand-by status and vice versa.

#### 4.6 - KEYBOARD LOCK FUNCTION

On the instrument it's possible to lock completely the keyboard.

This function is particularly useful when the regulator is reachable by the users and it's desired to avoid any modification.

To activate the keyboard lock it's enough program the par. "Lo" to a different value to oF.

The value program to this parameter it is the time of inactivity of the keys after which the keyboard will be locked.

Insofar not pressing any key for the time "Lo" the instrument automatically disable the normal functions of the keys.

When the keyboard is lock, if any of the key is pushed, on the display will appear "Ln" to indicate the active lock.

To unlock the keyboard it's enough to contemporarily push key P and UP and keep them pushed for 5 sec., after which the label "LF" will appear on the display and all the keys functions will be available again.

### 5 - PROGRAMMABLE PARAMETERS TABLE

Par.	Description	Range	Def.	Note
1	LS	Minimum Set Point	-58 ÷ HS °C/°F	-50
2	HS	Maximum Set Point	LS ÷ 302 °C/°F	100
3	SP	Set Point	LS ÷ HS	0.0
4	CA	Probe Calibration	-30 ÷ 30.0 °C/°F	0.0
5	ru	Unit of measurement	°C - °F	°C
6	dP	Decimal point	on - oF	on
7	Ft	Measurement filter	oF ÷ 20.0 sec	2.0
8	d	Differential (Hysteresis)	0.1 ÷ 30.0 °C/°F	2.0
9	t1	Activation time output Out for probe broken	oF ÷ 999 min.	oF
10	t2	Deactivation time output Out for probe broken	oF ÷ 999 min	oF
11	HC	Function mode output Out	H - C	C
12	P1	Out delay at switch on	oF ÷ 999 min	oF
13	P2	Out delay after switch off	oF ÷ 999 min	oF
14	P3	Out delay between switching-on	oF ÷ 999 min	oF
15	od	Delay at power on	oF ÷ 999 min.	oF
16	HA	Relative High temperature Alarm threshold	oF ÷ 99.9 °C/°F	oF
17	LA	Relative Low temperature Alarm threshold	oF ÷ 99.9 °C/°F	oF
18	Ad	Temperature Alarms Differential	0.1 ÷ 30.0 °C/°F	1.0
19	At	Temperature Alarms delay	oF ÷ 999 min	oF
20	PA	Temperature Alarms delay at power on	oF ÷ 999 min.	120
21	Fb	Function mode key DOWN: oF= No Function 1= ON/STAND-BY	oF / 1	oF
22	Lo	Keyboard lock function delay	oF ÷ 25 min.	oF
23	PP	Access Password to parameter functions	oF ÷ 999	oF

## 6 - PROBLEMS, MAINTENANCE AND GUARANTEE

### 6.1 - SIGNALLING

#### Error Signalling:

Error	Reason	Action
<b>E1</b> <b>-E1</b>	The probe may be interrupted (E1) or in short circuit (-E1), or may measure a value outside the range allowed	Check the correct connection of the probe with the instrument and check the probe works correctly
<b>EE</b>	Internal memory error	Check and if necessary re-programme the parameters function.

#### Other Signalling:

Message	Reason
<b>od</b>	Delay in switching on in progress
<b>Ln</b>	Keyboard lock
<b>HI</b>	Maximum temperature alarm in progress
<b>LO</b>	Minimum temperature alarm in progress

### 6.2 - CLEANING

We recommend cleaning of the instrument only with a slightly wet cloth using water and not abrasive cleaners or solvents.

### 6.3 - GUARANTEE AND REPAIRS

The instrument is under warranty against manufacturing flaws or faulty material, that are found within 12 months from delivery date.

The guarantee is limited to repairs or to the replacement of the instrument.

The eventual opening of the housing, the violation of the instrument or the improper use and installation of the product will bring about the immediate withdrawal of the warranty's effects.

In the event of a faulty instrument, either within the period of warranty, or further to its expiry, please contact our sales department to obtain authorisation for sending the instrument to our company.

The faulty product must be shipped to SIKA with a detailed description of the faults found, without any fees or charge for SIKA, except in the event of alternative agreements.

## 7 - TECHNICAL DATA

### 7.1 - ELECTRICAL DATA

Power supply: 12 VAC/VDC, 115 VAC, 230 VAC +/- 10%

Frequency AC: 50/60 Hz

Power consumption: 3 VA approx.

Input/s: 1 input for temperature probes: PTC (KTY 81-121, 990  $\Omega$  @ 25 °C) or NTC (103AT-2, 10K $\Omega$  @ 25 °C).

Output/s: 1 relay output SPST-NO (16A-AC1, 6A-AC3 250 VAC, 1HP 250VAC, 1/2HP 125 VAC) or SPDT 16A-AC1, 6A-AC3 250 VAC, 1HP 250VAC, 1/2HP 125 VAC)

Electrical life for relay outputs: SPST-NO: 100000 op. ; SPDT: 50000 op. (om. VDE)

Action type: type 1.B (EN 60730-1)

Overvoltage category: II

Protection class: Class II

Insulation: Reinforced insulation between the low voltage part (supply 115/230 V and relay output) and front panel; Reinforced insulation between the low voltage section (supply 115/230 V and relay output) and the extra low voltage section (inputs); Reinforced between supply and relay output; No insulation between supply 12 V and inputs.

### 7.2 - MECHANICAL DATA

Housing: Self-extinguishing plastic, UL 94 V0

Dimensions: 33 x 65 mm, depth 50 mm

Weight: 105 g approx.

Mounting: Flush in panel (thickness max. 5 mm) in 25 x 58 mm hole

Connections: 2,5 mm<sup>2</sup> screw terminals block

Degree of front panel protection: IP 65 (NEMA 3S) mounted in panel with gasket

Pollution situation: 2

Operating temperature: 0 T 50 °C

Operating humidity: < 95 RH% without condensation

Storage temperature: -25 T +60 °C



### 7.3 - MECHANICAL DIMENSIONS, PANEL CUT-OUT AND MOUNTING [mm]

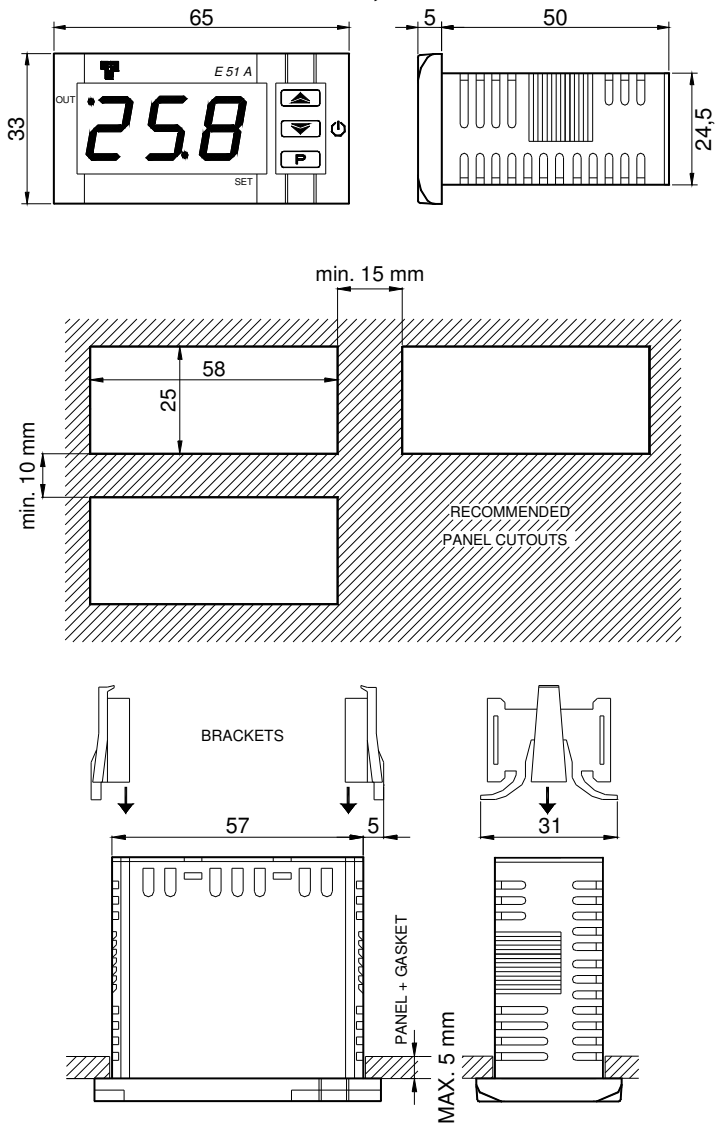

### 7.4 - FUNCTIONAL FEATURES

Temperature Control: ON/OFF mode

Measurement range: NTC: -50...109 °C / -58...228 °F; PTC: -50...150 °C / -58 ... 302 °F

Display resolution: 1 ° or 0,1° (range -19.9 ...99.9 °)

Overall accuracy: +/- (0,5 % fs + 1 digit)

Sampling rate: 130 ms.

Display: 3 Digit Red h 14 mm

Software class and structure : Class A

Compliance: ECC directive 2004/108/CE (EN55022: class B; EN61000-4-2: 8KV air, 4KV cont.; EN61000-4-3: 10V/m; EN61000-4-4: 2KV supply, inputs, outputs; EN61000-4-5: supply 2KV com. mode, 1 KV\ diff. mode; EN61000-4-6: 3V), 2006/95/CE (EN 60730-1, EN 60730-2-7, EN 60730-2-9)

### 7.5 - INSTRUMENT ORDERING CODE

**E51A a b c d e f g h h ii**

#### **a : POWER SUPPLY**

**D** = Supply 230 VAC

**C** = Supply 115 VAC

**F** = Supply 12 VAC/VDC

#### **b : INPUT**

**N** = Input NTC

**P** = Input PTC

#### **c : OUTPUT**

**S** = Out Relay SPDT 16A-AC1

**R** = Out Relay SPST-NO 16A-AC1